



CURVED-RADIUS SNAP-ON SEAM

CR-SS10



www.dmimetals.com

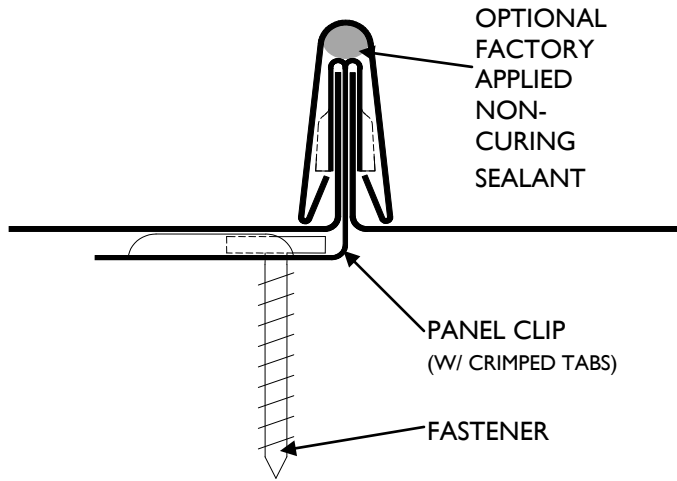

SEAM CROSS SECTION
(RADIi LESS THAN 35'-0" -
LEG HEIGHT IS 3/4")

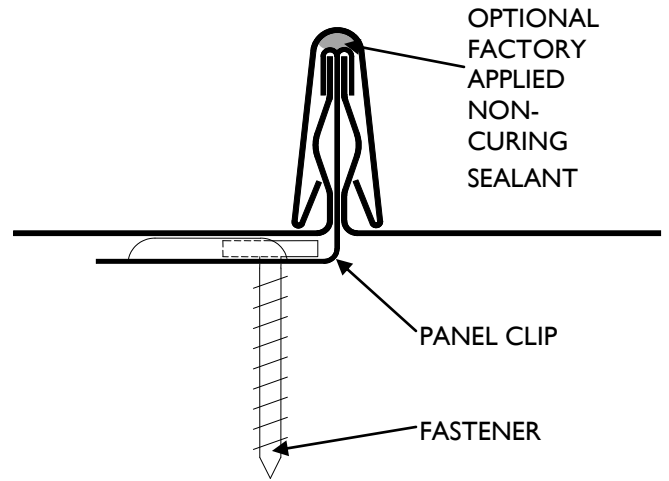

SEAM CROSS SECTION
(RADIi GREATER THAN 35'-0")

CR-SS10 PANEL PROFILE:

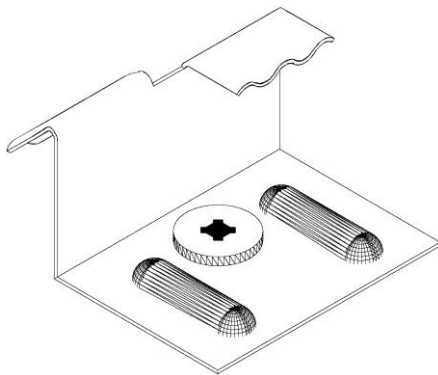

CR10 CLIP
(W/ CRIMPED TABS)

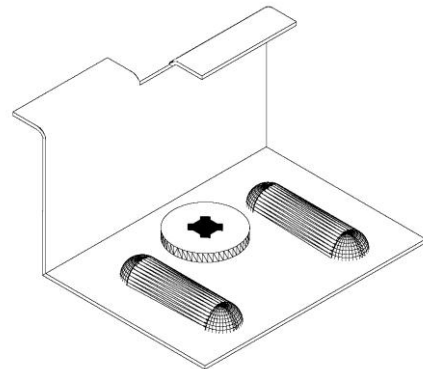

CR10 CLIP

CURVED-RADIUS SNAP-ON SEAM CR-SS10 (continued)

STANDARD PRODUCT OFFERING

24 ga. Steel and .032 Aluminum:

MODEL NO.	SEAM ON-CENTER
CR-SS1012	12 1/4"
CR-SS1014	14"
CR-SS1018	18"

16 oz. and 20 oz. Copper:

MODEL NO.	SEAM ON-CENTER
CR-SS1013	13.5"

Custom panel widths are available. Consult DMI for costs and lead times.

PRODUCT: CURVED-RADIUS CR10 is a non-structural curved snap-on-seam system. The system is designed with two components: the panel pan and the seam cover. CURVED-RADIUS is a non-directional panel system allowing installers more control during installation over seam layout and symmetry of the panel area. CURVED-RADIUS panels utilize a 5/8"-7/8" high panel leg with a continuous interlocking groove for radii greater than 35'-0". For radii less than 35'-0", a lower leg height is used in order for the panel to achieve the desired radius. For radii less than 45'-0" and greater than 35'-0" panel leg is button punched en lieu of a continuous bead.

NOTE: Continuous lengths from 4'-0" (min.) up to 70'-0" (max.) is standard. Lengths over 53' require special hauling permits. Contact DMI for details.

Oil-canning, the slight waviness inherent with light gauge metal, does not affect the finish or structural integrity of the panel and is therefore not cause for rejection.

ROOF ASSEMBLIES: CURVED-RADIUS requires a solid substrate since it is a non-structural panel system. This system may be installed over plywood sheathing or corrugated metal deck.

PRODUCT USES AND APPLICATIONS: Product uses include curved roofing, barrel vaults, curved canopies, and curved soffit. This system may be installed on tapered roof areas (see the COMPOUND-CURVE CC10 section of this literature for information) and may be curved with a concave or convex radius.

ADVANTAGES:

1. Continuous Interlocking Seam: high seam hold-down strength (for radii 35'-0" or less)
2. Optional Factory Applied Non-Curing Sealant: superior watertightness
3. Engineered Snap-Together Design: easy installation
4. Expansion Clips: allows for unlimited thermal expansion and contraction
5. Anti-Siphoning Seam Design: prevents water infiltration
6. Custom Panel Widths Available: consult DMI for additional information

RADIUS GUIDELINES:

GAGE / MATERIAL	MINIMUM CONVEX RADIUS	MINIMUM LAYOVER RADIUS
24 GA.	3'	25'
22 GA.	8'	35'
.032 AL	2'-6"	20'
COPPER	2'	20'

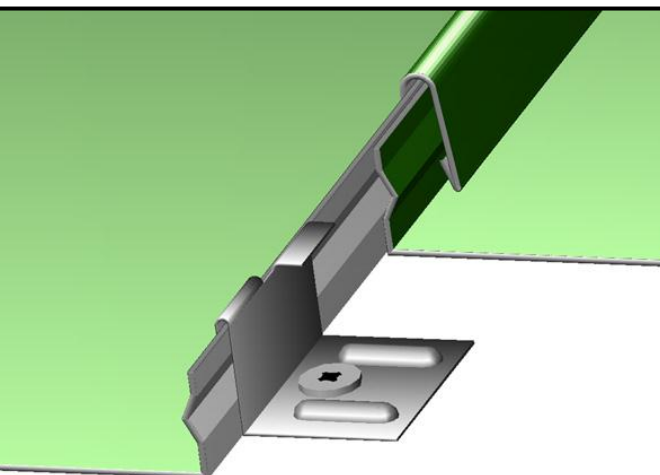

DIMENSIONAL METALS, INC.

DMI has specialized in the manufacturing of Architectural Metal Panel Systems and Fabricated Architectural Sheet Metal for the construction industry for over 20 years. We use the most technologically advanced Fixed Base Roll-Forming Equipment with in house quality control so that we can offer the highest product quality available.

Please contact our Engineering Department today for technical assistance.

Headquarters
58 Klema Drive North
Reynoldsburg, OH 43068
Tel: 800-828-1510
Fax: 740-927-3319

North Carolina
Tel: 800-919-1510

Web: www.dmimetals.com
E-mail: sales@dmimetals.com

